

G-RAIL 5030 Bolted Rail Clips

TECHNICAL SPECIFICATIONS

- Max side load 70 kN
- Lateral adjustment 16 mm
- Bolt M20 Grade 8.8
- Tightening Torque 320 Nm
- Steel Quality St52-3

CLIPS NO	X	W	Weight (Kg)
G-RAIL 5030	23	46	0,740

MAIN FEATURES

1. G-RAIL 5030 bolted rail clip, which is produced from a forged part, enables ease of assembly thanks to its special desing.
2. The clips can preferred for rails with or without pads.
3. The main part is locked to rail with special bolt.

1 RAIL WITH PAD

2 RAIL WITHOUT PAD

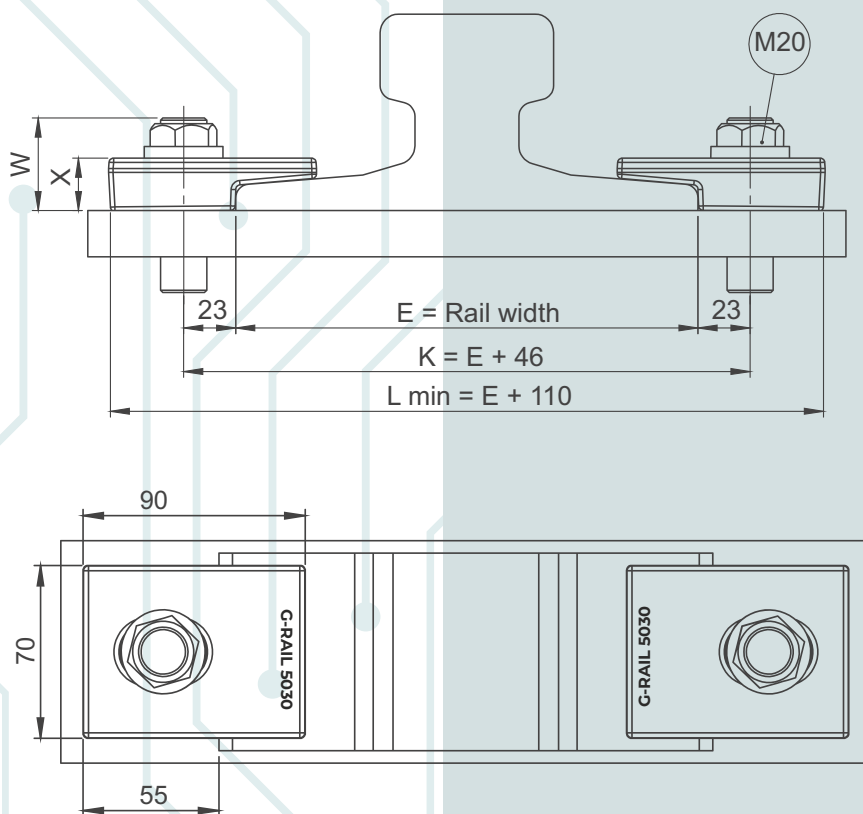

Flange nut can also be used on request.
Please consult us for using flange nut.

5030

G-RAIL 5030 Bolted Rail Clips

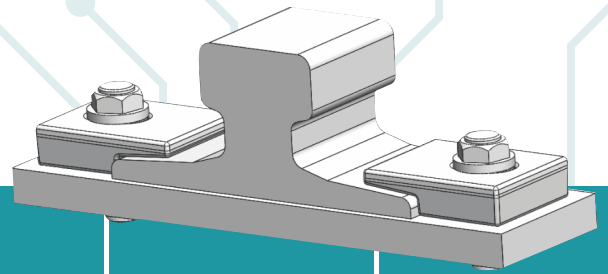

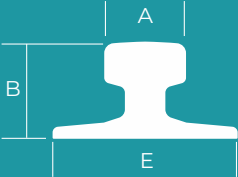
	A	B	E	Without Pad	Without Pad	With Pad
A65	65	75	175	43,1	5030	5030 P
A75	75	85	200	56,2	5030	5030 P
A100	100	95	200	74,3	5030	5030 P
A120	120	105	220	100	5030	5030 P
A150	150	150	220	150,3	5030	5030 P
CR 104	63,5	127	127	51,59	5030	5030 P
CR 105	65,1	131,8	131,8	52,09	5030	5030 P
CR 135	76,2	146	131,8	66,97	5030	5030 P
CR 171	101,6	152,4	152,4	84,83	5030	5030 P
CR 175	102,4	152,4	152,4	86,8	5030	5030 P
MRS 87 A	101,6	152,4	152,4	86,8	5030	5030 P
MRS 125	120	180	180	125	5030	5030 P
36 E1	60	130	100	36,26	5030	5030 P
40 E1	67	138	125	40,95	5030	5030 P
46 E4	65	145	135	46,9	5030	5030 P
49 E1	67	149	125	49,39	5030	5030 P
50 ES	67	148	135	49,9	5030	5030 P
54 E1	70	159	140	54,77	5030	5030 P
60 E1	72	172	150	60,21	5030	5030 P

CLIP CAN BE USED WITH MORE TYPE OF RAILS THAN THOSE LISTED.

INSTALLATION INSTRUCTIONS:

The main component is first positioned on the bolt against the rail and the special washer is then positioned on the main component. The nut is hand tightened. Hammer is used for tighter contact. The main component is in position, use an electrical or pneumatic wrench to torque the nut. Please contact G-RAIL for full installation instructions.

WELD DETAIL

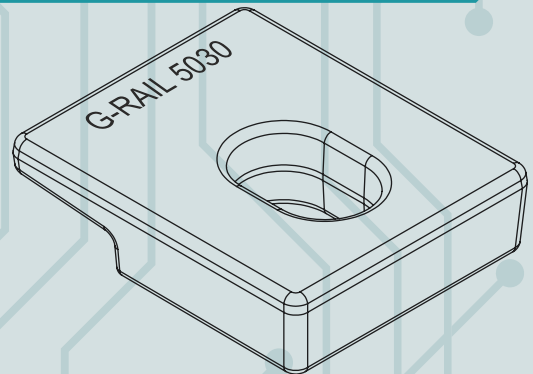

G-RAIL NO DOUBT ABOUT CRANE RAILS AND FASTENING SYSTEM



Przedstawiciel handlowy w Polsce:

DETRANS
ul. Damrota 2
41-800 Zabrze,
NIP: 6482772915

Jacek Kohn
Telefon: +48 511 973 972
E-mail: j.kohn@detrans.pl

